

Visakhapatnam Chapter

*Proceedings of Indian Geotechnical Conference 2020
December 17-19, 2020, Andhra University, Visakhapatnam*

Reliability Analysis of Settlement of a Foundation Resting Over a Circular Void

Kumar Shubham^{1,2}, Subhadeep Metya³[0000-0003-0622-6978] and Gautam Bhattacharya⁴

¹ Research Scholar, Civil Engineering Department, NIT Jamshedpur, Jharkhand

² Assistant Professor, Arka Jain University, Jamshedpur, Jharkhand

³ Assistant Professor, Civil Engineering Department, NIT Jamshedpur, Jharkhand

⁴ Professor (Retd.), Civil Engineering Department, IEST, Shibpur, West Bengal
shubham13202007@gmail.com

Abstract. Presence of any type of excavation or void underneath the foundation of a structure is one of the factors which affect the stability and may cause extreme damage to the structure. The factors affecting the bearing capacity and settlement of foundation are soil properties, operational conditions, void size, location of the void, number of voids and depth of foundation. Any subsurface development will create ground vibrations that subsequent in-ground settlements and lateral movements, which can make harm the current surface and underground structures. Thus, the existence of underground cavities for significant and immense structures, such as pipelines and tunnels affect its serviceability. Finite Element Method (FEM) has gained popularity in the field of subway development using computing technology for the analysis of surface settlement. This paper shows an analysis of the effect of excavation below the shallow foundation on its stability and a reliability approach to study the same. Finite Element Analysis package PLAXIS 2D is used for the analysis of the performance of footing over a void under different boundary conditions. A model is prepared and the analysis was done by varying the depth of void within the pressure bulb of a strip foundation, the eccentricity of the void from the centre of foundation and the load of the superstructure. The result of the varying depth of the void, the position of void in the horizontal axis and the load of the building on the ground surface settlement shown in terms of the Gaussian distribution curve. The settlement data is further used to carry out the reliability assessment to check the dependability of the study.

Keywords: Foundation Stability, Circular Void, PLAXIS 2D, Reliability Analysis, Gaussian Distribution

1 Introduction

The bearing capacity of the foundation soil is the main factor which affects the structural stability of any structure. The presence of any type of excavation or void underneath the foundation of a structure is one of the major factors which affect the stability and may cause extreme damage to the structure. The factors affecting the

bearing capacity and settlement of foundation are soil properties, operational conditions, void size, location of the void, number of voids and depth of foundation. Due to rapid urbanization and growing population, the construction technology has evolved and shifted towards a new phase where underground buried conduits and utility tunnels have become popular for installing electricity cables, water supply pipes, wire communications, gas supply, etc., and the foundation of new construction may exist in the vicinity of the existing buried conduits or utility tunnel due to land scarcity issues. There are various geological studies which show that the presence of voids or cavities may be due to man-made activities (mining, construction of tunnels, aqueducts, conduits and underground water tanks) or natural activities (the dissolution of minerals salts, dolomite, gypsum etc., the formation of tension cracks and the presence of organic materials in the stratified soil). Thus, the existence of underground cavities for significant and immense structures, affect the serviceability of the structure.

In recent years, there has been a development of interest among the researchers and also the increased dependability on the probabilistic approach or reliability analysis in the field of geotechnical engineering because geotechnical parameters are highly uncertain or random. Foundation stability analysis is one of the important areas where the recent trend is to determine the probability of failure instead of, or complementary to, the conventional methods based on determining the settlement. Many researchers have worked on developing a probabilistic model for progressive failure of slopes [1, 7]. It has been found in some research that the stability of footing can be significantly affected when the void is located within the critical region under the footing using upper bound limit analysis [2, 10]. A calculation formula can also be used for estimating the critical conditions of foundation placed above the voids using 2D finite element analysis and then using the reliability techniques to analyse the data [4, 5, 9]. Construction of underground voids like tunnels inevitably induces varying degrees of ground movement towards the excavation resulting in ground surface settlement. This ground settlement is likely to affect adjacent buildings and leads to environmental hazards. Some methods have been developed to determine surface settlement and lining stresses induced by tunnelling based on field measurements [8]. Other than studies on green-field settlement prediction due to tunnelling and its control, there are several numerical studies, which investigated the effect of tunnelling on foundations. This paper shows an analysis of the effect of excavation below the shallow foundation on its stability and a reliability approach to study the same. Finite Element Analysis package PLAXIS 2D is used for the analysis of the performance of footing over a void under different boundary conditions.

2 Formulation

The most common empirical method is the Gaussian curve to predict ground movements. The Gaussian curve has been used since long to predict settlement in case of excavation under the foundation [8] as shown in Fig. 1. The ground Loss (GL) and the standard deviation 'i' of the Gaussian curve are the two parameters that need

to match with the surface settlement. The finite element method is used for analysing the bearing capacity and settlement of footing over the void using the data available in the literature. The design of experiments can be performed using full factorial design and then the trial sets are analysed using the finite element method. A linear surface method is then used to analyse these sets of input and output parameters which is further used to develop a limit state function and thus the reliability index is determined using First order reliability method. The first-order model with controlled input parameters x_1 and x_2 to get a simple response y using response surface method is shown in Equation 1.

$$y = \beta_0 + \beta_1 x_1 + \beta_2 x_2 + \beta_{12} x_1 x_2 + \epsilon \quad (1)$$

In the polynomial equation, ϵ represents error due to uncontrolled parameters and experimental error. The coefficients β_1 and β_2 are the main effects, while β_{12} is a two-way interaction effect. In an experiment the coefficients β_0 , β_1 , β_2 and β_{12} calculated accurately by changing x_1 and x_2 to get a response y . The load of a system is 'S' and resistance is 'R', these values are uncertain. These values have mean-variance and covariances. Margin of safety which represents the performance of the function is $M = R - S = 0$. The probability of failure is $P_f = P[(R - S) \leq 0]$

Cording and Hansmire [3] defined the ground loss as the volume of soil that is displaced across the perimeter of a tunnel. It is often defined in terms of volume lost per unit length of the tunnel constructed. The percentage ground loss (GL) is defined as follows:

$$GL = \frac{V_i}{V_o} \times 100 \quad (2)$$

where V_i = Trough volume, V_o = Tunnel opening volume (πr^2) and r = Radius of the tunnel. Based on the shape of the Normal distribution curve, Peck [8] showed that the maximum settlement $S_{v, \max}$ can be given by

$$S_{v, \max} = \frac{0.314 \times GL \times D^2}{i} \quad (3)$$

where 'D' = diameter of the tunnel and $S_{v, \max}$ = maximum settlement occurring above the tunnel axis. The settlement at various points of the trough is then given by,

$$S_v(y) = S_{v, \max} \cdot \exp\left(\frac{-y^2}{2i^2}\right) \quad (4)$$

where 'y' = horizontal distance from the tunnel axis and 'i' = horizontal distance from the tunnel axis to the point of inflexion. Some researchers suggested that the 1–2% of ground loss (GL) is usually found for stiff clay, 2–5% for soft clay and less than 1% for sandy soil [8]. It was also suggested that Gaussian distribution could be helpful to approximate subsurface settlement profiles [6].

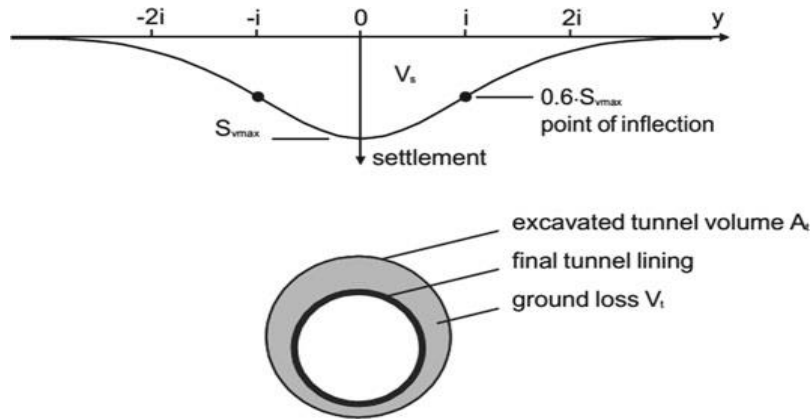

Fig. 1. Gaussian Curve for Settlement in presence of void [6]

3 Methodology

3.1 Materials, Structure & PLAXIS Model

Presence of voids under foundation affects bearing capacity and settlement of footing. Many studies have been carried out to know the significant effect on the footing. Wang et.al adopted three failure mechanisms to formulate equations for the collapse load of footing over the circular void. Fig. 2 shows failure mechanisms considered by Wang and Hsieh [10] in which it was observed that the failure under the footing with the void is punching shear failure in which shear planes are confined to soil mass causing the collapse of soil into the void just below the footing.

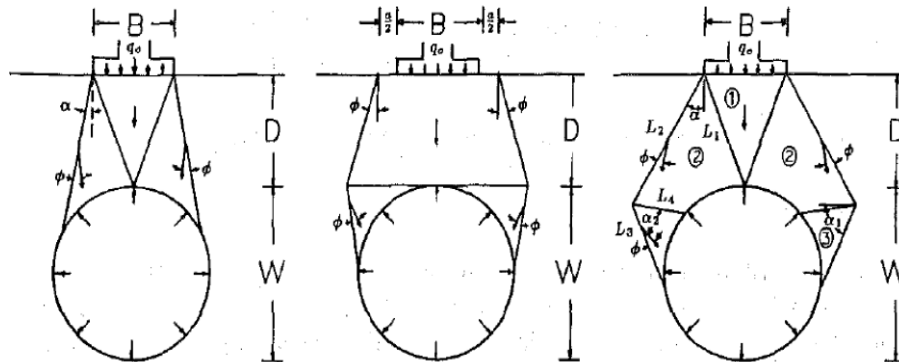

Fig. 2. Failure mechanism of footing collapse [10]

The settlement analysis has been done by considering the effect of change in depth, the horizontal distance from the centre of foundation and the loads. The same is modelled and simulated in PLAXIS 2D as shown in Fig. 3 and results are compared. In the present study, the foundation soil mass was represented the finite number of dis-

crete elements interconnected by nodal points, Triangular element with 15- nodes were used as soil element. In the later section, the footing was analysed for different conditions. Fig. 3 shows the geometrical model of footing and the values of the various associated parameters is mentioned in Table 1.

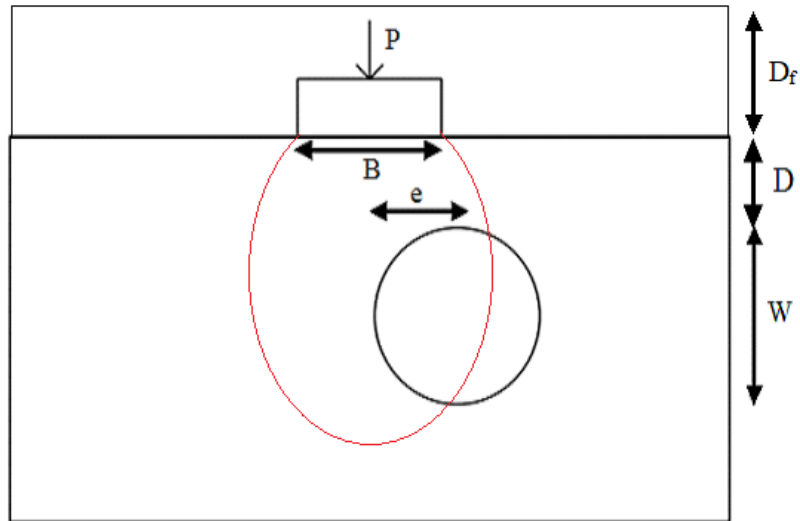

Fig. 3. Definition sketch of the model used in PLAXIS 2D

Table 1. Values of parameters used in the PLAXIS 2D model

Parameters	Description (Soil)	Description (Void Lining)	Description (Concrete)
Material	Mohr Coloumb	Linear Elastic	Linear Elastic
Material Behavior	Undrained	Non-Porous	Non-Porous
γ_{unsat} [kN/m ³]	16	22	24
E_{ref} [kN/m ²]	26604000	-	5000
c_{ref} [kN/m ²]	5	-	-
ν	0.35	0.15	0.2
ϕ [°]	20	-	-
EI [kN m ²]	-	6.25×10^6	-
EA [kN m ²]	-	3.20×10^4	-

In this study, the depth of the shallow foundation (D_f) and width of the footing (B) has been considered as per the general construction practice as 2 m and 1.5 m respectively. Then the load and the void position within the pressure bulb is varied. In the first case, depth of void (D) from the base of footing is gradually increased from 0.5 m to 3 m keeping an interval of 0.25 m. Then, for each vertical position i.e. specific depth, horizontal position (e) is varied from 0 m to 10 m keeping an interval of 2 m. At last,

the load of the structure acting on the footing (P) is varied from 50 kN/m^2 to 300 kN/m^2 keeping other parameters constant.

3.2 Reliability Analysis

For carrying out the analysis, Design of Experiment is used at a 2-level with 3 factors at full factorial design. The vertical depth of void, horizontal distance of the void and the load from the structure are considered as the variables. The mean settlement is calculated for different cases. The corresponding values of reliability index and probability of failure are then calculated.

4 Results

4.1 Effect of Depth

The settlement profile was observed in different cases by varying the depth of tunnel location varying from 0.5 m to 3 m. The graph shown in Fig. 4 is the Gaussian distribution curve for tunnel location from 0.5 m to 3 m. The vertical settlement reduces from the depth of 2.5 - 3 m. It can be inferred that the settlement when the void is present within the pressure bulb increases minimally up to a depth of 1.75 m but takes a sudden pattern curve up to 2.5 m.

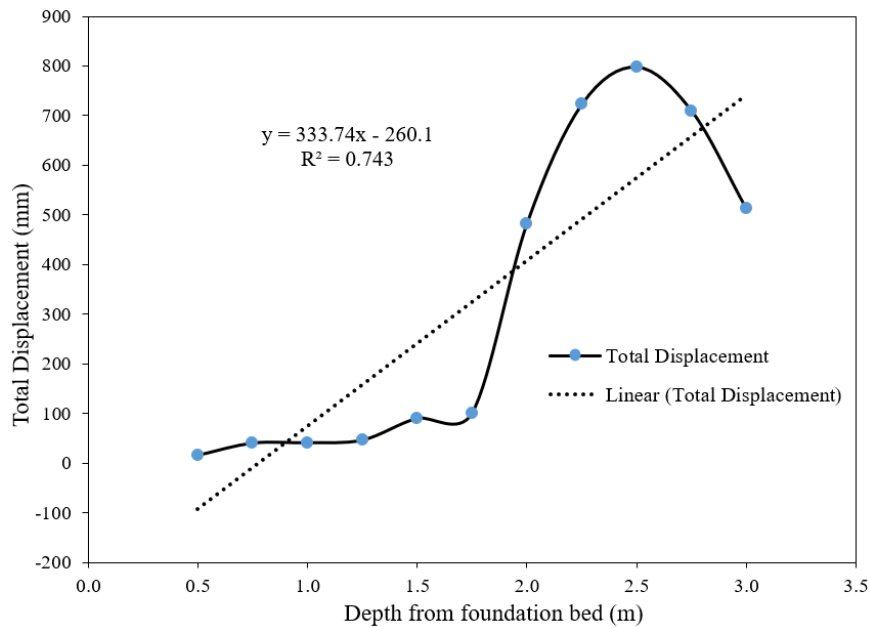

Fig. 4. Variation of total displacement with depth from foundation bed

4.2 Effect of Horizontal Distance

The settlement profile was observed in different cases by varying the horizontal distance of tunnel varying from 0m to 10 m from the centre of the foundation. The graph shown in Fig. 5 is the Gaussian distribution curve for tunnel location from 0 m to 10 m. The settlement of the foundation within the 1.75 m of depth is within the permissible limit while there is an abrupt increase in the settlement.

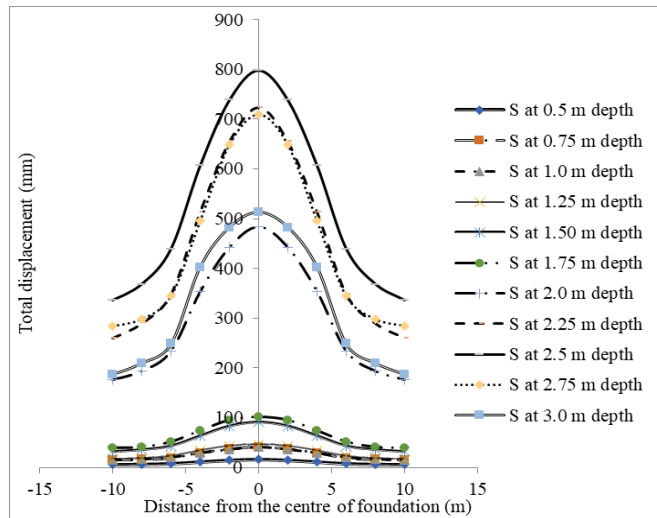

Fig. 5. Variation of total displacement with the horizontal distance from the centre of the foundation

4.3 Effect of Load Variation

The settlement profile was observed in different cases by varying the load from the structure from 50 kN/m² to 350 kN/m². The graph shown in Fig. 6 is the Gaussian distribution curve for tunnel location from 50 kN/m² to 350 kN/m². The settlement of the foundation is more or less having a common gradual increasing pattern. With the increase in the load, it can be observed that the total vertical displacement also increases.

4.4 Regression Equation

If the factors are analysed and a correlation equation between the Vertical position of void from foundation bed (W+D), Horizontal position of void from centre of foundation (e) and the vertical load (P) is obtained as mentioned in Equation 5:

$$\begin{aligned}
 \text{Settlement} = & 112.9 - 11.74V - 0.000350H + 0.3597P + 0.0007V \times H - 0.04657V \times P \\
 & + 0.000001H \times P - 0.000002V \times H \times P \quad (5)
 \end{aligned}$$

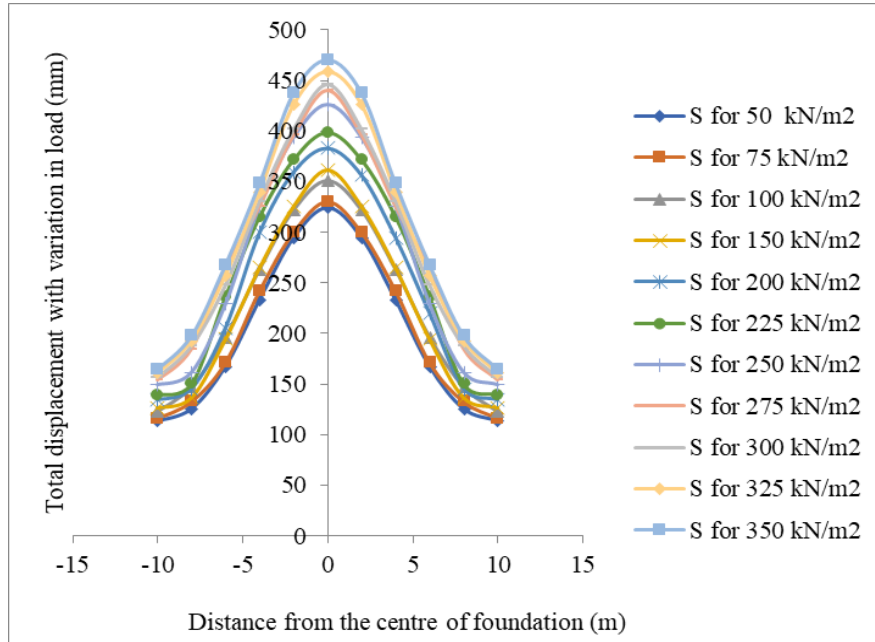

Fig. 6. Variation of total displacement with the distance from the centre of the foundation with a change in load

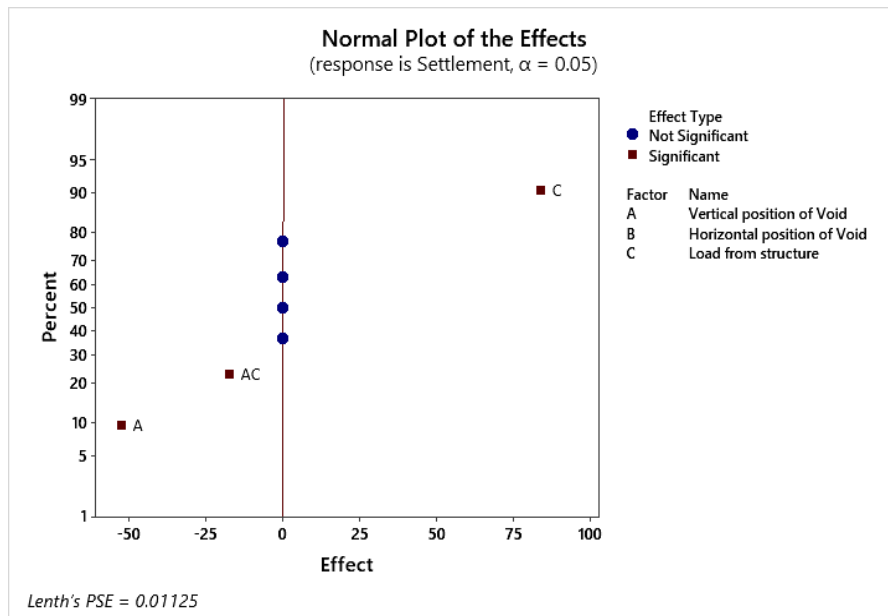

Fig. 7. Effects of various factors and their interrelations

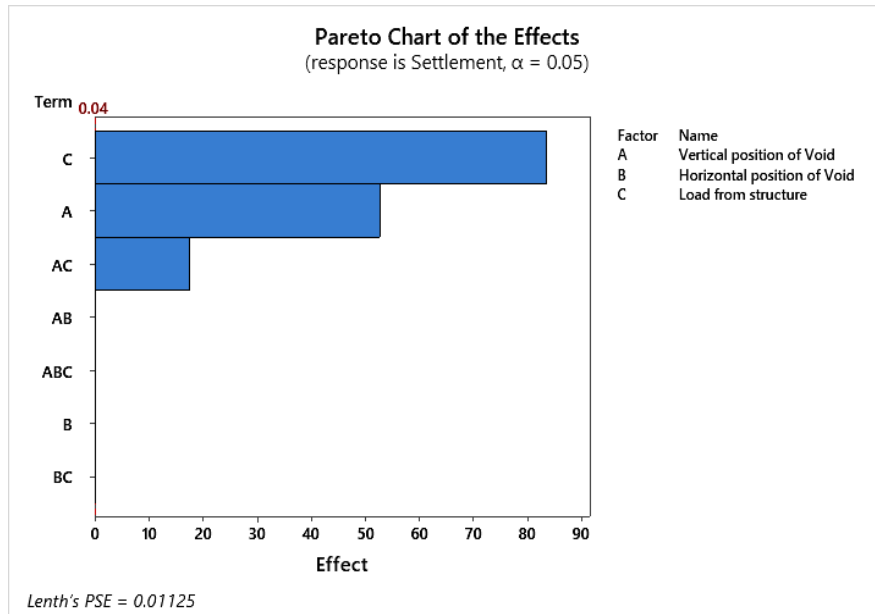

Fig. 8. The Pareto Chart of the effects

It can be inferred from the regression equation in Equation 5 that the vertical depth of void and the variation in the load has a predominant effect on the settlement of the foundation. The interrelation of the factors can be observed in Fig. 7 and Fig. 8.

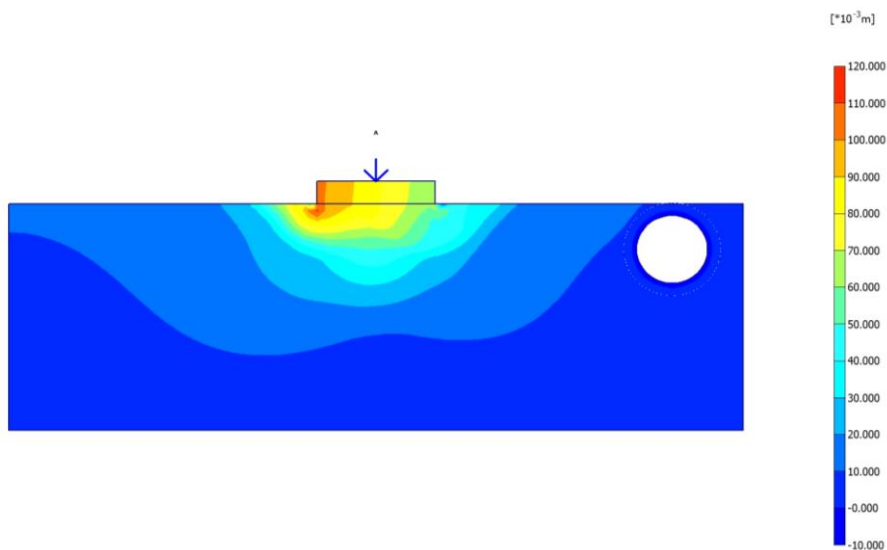

Fig. 8. One of the cases obtained through DOE

4.5 Reliability Index and Probability of Failure

The DOE is used to develop a 2-level 3 factored full factorial design to obtain the different cases of analysis through the MINITAB software. These conditions were further analysed using PLAXIS 2D software to determine the settlement of the foundation as shown in Fig. 8. This is then processed through EXCEL-XSTAT to obtain the reliability index (β) which is calculated as 0.894 and the Probability of Failure (P_f) comes to be 0.185. Also, the value of Cronbach Alpha obtained is 0.965 which shows a consistency in the data observed through the various steps of calculation. The value of the reliability index and the probability of failure shows hazardous condition if we consider the risk according to the settlement of the foundation.

5 Conclusions

Based on the present study, the following concluding remarks can be made:

1. The behaviour of void depth from 0 to 3 m in a given soil conditions is studied with the help of Plaxis 2D software to generate a graph of vertical settlement versus depth of the tunnel and hence, the ground surface settlement is demonstrated by Gaussian distribution curve. As the depth of the centre of tunnel increases from 0 to 3 m the surface settlement first increases and then decreases, it means the influence of tunnel location on ground settlement decreases as the depth of void increases after a certain depth. It can be concluded that within a certain range of vertical location, the effect of depth of void is maximum.
2. Due to an increase in depth of void, the overburden pressure increases and simultaneously values of axial force, bending moment and shear force on tunnel lining also get increased.
3. Due to an increase in the building load (from 50 to 350 kN/m²) the values of extreme total displacement on the ground surface, axial force, bending moment and shear force on tunnel will also increase. There is no phenomenon observed that demarcates the inverse effect of loading on the settlement. However, it has been observed that with the increase in horizontal distance from the centre of foundation, the settlement decreases.
4. Presence of uncertainties in the results of the failure of the structure which are not found using a deterministic approach. Therefore reliability analysis was performed, using first-order reliability method, the reliability index for footing over single void is found as 0.894 and probability of failure of structure is found as 0.185. From USACE (1997) chart the structure is hazardous under standard conditions.

References

1. Babu GLS, Srivastava A (2007) Reliability analysis of allowable pressure on shallow

- foundation using response surface method. *Comput Geotech* 34:187–194. doi: 10.1016/j.compgeo.2006.11.002
2. Badie A, Wang MC (1984) Stability of spread footing above void in clay. *J Geotech Eng* 110:1591–1605. doi: 10.1061/(ASCE)0733-9410(1984)110:11(1591)
 3. Cording EJ, Hansmire WH (1975) Displacement around Soft Ground Tunnels. In: 6th Pan-American Conference of Soil Mechanics and Foundation Engineering. Buenos Aires, pp 571–633
 4. Fenton GA, Zhou H, Jaksa MB, Griffiths D V. (2003) Reliability Analysis of a Strip Footing Designed Against Settlement. In: ICASP9, Int. Conf. on Applications of Statistics and Probability in Civil Engineering. pp 1271–1277
 5. Kiyosumi M, Kusakabe O, Ohuchi M (2011) Model Tests and Analyses of Bearing Capacity of Strip Footing on Stiff Ground with Voids. *J Geotech Geoenvironmental Eng* 137:363–375. doi: 10.1061/(asce)gt.1943-5606.0000440
 6. Mair RJ, Taylor RN (1997) Theme lecture: Bored tunnelling in the urban environment. *Soil Mech Found Eng* 14:2353–2386
 7. Metya S, Bhattacharya G (2014) Probabilistic Critical Slip Surface for Earth Slopes Based on the First Order Reliability Method. *Indian Geotech J* 44. doi: 10.1007/s40098-013-0089-8
 8. Peck RB (1969) Deep excavations and tunneling in soft ground. In: 7th ICSMFE. pp 225–290
 9. Schweiger HF, Peschl GM (2005) Reliability analysis in geotechnics with the random set finite element method. *Comput Geotech* 32:422–435. doi: 10.1016/j.compgeo.2005.07.002
 10. Wang MC, Hsieh CW (1987) Collapse Load of Strip Footing Above Circular Void. *J Geotech Eng* 113:511–515